

# KK Door Styles

Kitchen Kompact, Inc.  
911 E. 11th St. (47130)  
P.O. Box 868  
Jeffersonville, IN 47131-0868  
TEL: 812/282-6681  
FAX: 812/282-7880  
www.kitchenkompact.com



**Lynwood Maple:** Door frames are made of solid hard maple, mortised and tenoned. The raised panel insert is made of warp-resistant engineered wood for greater stability, with a sliced hard maple veneer face and back.

**Mellowood Maple:** Door frames are mortised and tenoned construction of solid maple. The flat plywood insert is a three-ply panel with a rotary cut hard maple veneer face.

**Richwood Lite and Richwood Lite Cathedral:** Door frames are made of solid oak, mortised and tenoned, mounted flush to the face frame. The raised panel insert is made of warp-resistant engineered wood for greater stability, with a rotary cut red oak veneer face and back, and secured to the frame. Drawer heads have routed finger pulls.

**Chadwood2 "The Deuce" and Chadwood2 "The Deuce" Cathedral:** Solid Appalachian oak frames are joined by mortise and tenon. The flat plywood insert is a three-ply panel with a rotary cut red oak veneer face. Drawer heads have routed finger pulls.

**K Wood:** Select rotary cut red oak veneer — face and back — on solid warp-resistant medium density fiberboard, 5/8" thick with beveled edge for easy opening.

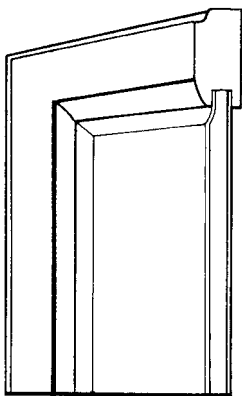

Lynwood Maple

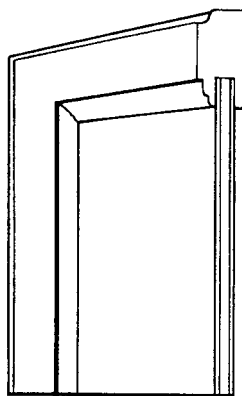

Mellowood Maple

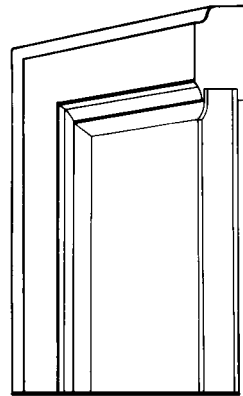

Richwood Lite

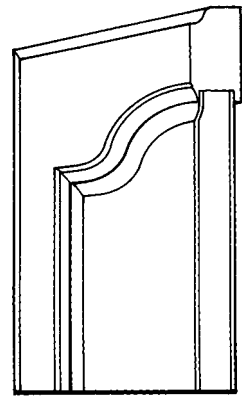

Richwood Lite Cathedral

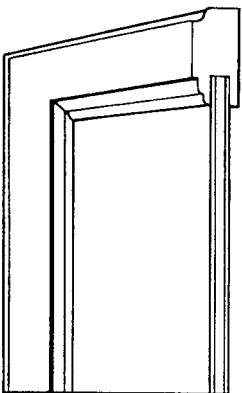

Chadwood2 "The Deuce"

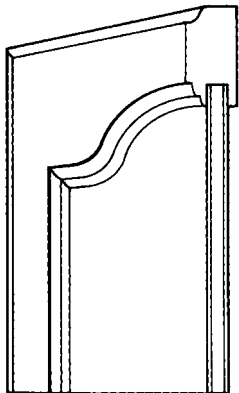

Chadwood2 "The Deuce"  
Cathedral

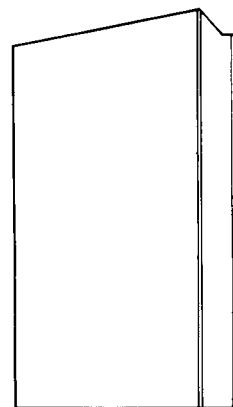

K Wood

# KK Wall Cabinets

Kitchen Kompact, Inc.  
911 E. 11th St. (47130)  
P.O. Box 868  
Jeffersonville, IN 47131-0868  
TEL: 812/282-6681  
FAX: 812/282-7880  
www.kitchenkompact.com



**Frames:** All frames are built of solid  $\frac{3}{4}$ " oak or maple, kiln-dried rails, joined by mortise and tenon with glue.

**End Panels:** End panels are full  $\frac{1}{2}$ " wood veneered plywood construction fastened to front frame with full  $\frac{1}{2}$ " tongue-in-groove to eliminate face nailing.

**Backs:**  $\frac{1}{8}$ " hardboard recessed in sides.

**Tops & Bottoms:**  $\frac{3}{16}$ " hardboard, dadoed into sides and interlocked into hanging rails and secured with adhesive for added strength.

**Hanging Rails:** Solid wood,  $\frac{3}{4}$ " x  $2\frac{5}{8}$ ", located at top and bottom.

**Shelves:** All wall cabinets feature adjustable shelves. A selection of six different heights is built into each 30" high unit. On 2-door wall units, the center 3" stile is used for center support of adjustable shelves. It is recommended that a  $\frac{1}{4}$ " hole be drilled in the back for additional center support. The extra shelf clip is provided. Shelves are  $\frac{1}{2}$ " engineered wood, with rounded front edge and printed wood grain.

**Hardware:** Chadwood2 "The Deuce," Richwood Lite, Mellowood Maple and Lynwood Maple feature concealed self-closing hinges — no door pulls included. K Wood features exposed self-closing hinges that open to 180°.

**Finish:** A 4-step process is applied to the exterior finish of all Kitchen Kompact Cabinets: Stain, Sealer, Sanding, and Catalyzed top coat. This finish is resistant to household chemicals such as water, beverages, mild acids — even nail polish. Richwood Lite, Chadwood2 "The Deuce," and K Wood all feature a special hand-wiped stain.

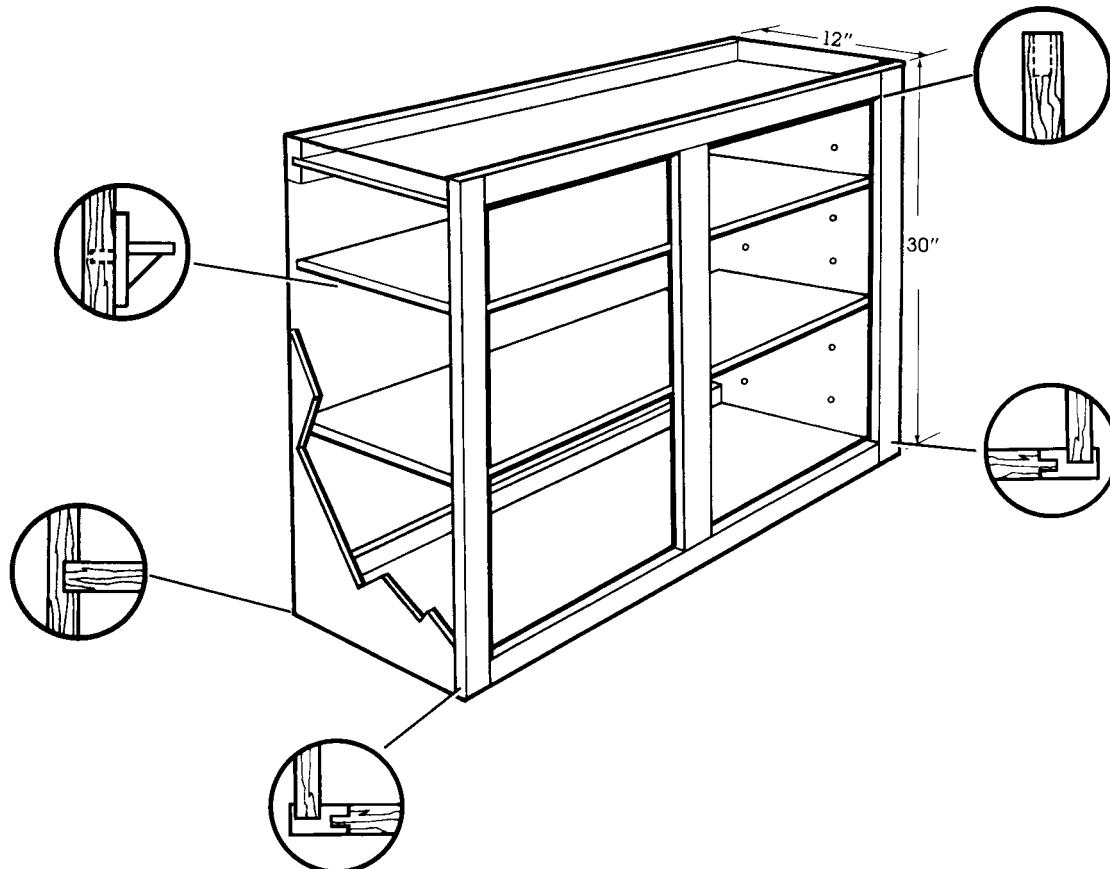

# KK Base Cabinets

Kitchen Kompact, Inc.  
911 E. 11th St. (47130)  
P.O. Box 868  
Jeffersonville, IN 47131-0868  
TEL: 812/282-6681  
FAX: 812/282-7880  
www.kitchenkompact.com



**Frames:** All frames are built of solid  $\frac{3}{4}$ " oak or maple, kiln-dried rails, joined by mortise and tenon with glue.

**End Panels:** End panels are full  $\frac{1}{2}$ " wood veneered plywood construction fastened to front frame with full  $\frac{1}{2}$ " tongue-in-groove to eliminate face nailing.

**Backs:**  $\frac{1}{8}$ " hardboard, recessed in sides.

**Bottoms:**  $\frac{3}{16}$ " hardboard, dadoed into sides and power nailed into supporting strips.

**Hanging Rails:** Solid wood,  $\frac{3}{4}$ " x  $1\frac{1}{2}$ ", located at top.

**Corners:** Wood blocks glued and power nailed.

**Toe Kick:**  $\frac{3}{4}$ " pine.

**Shelf:**  $\frac{1}{2}$ " engineered wood 11" deep dadoed into sides, with rounded front edge and printed wood grain.

**Hardware:** Chadwood2 "The Deuce," Richwood Lite, Mellowood Maple and Lynwood Maple feature concealed self-closing hinges – no door pulls included. K Wood features exposed self-closing hinges that open to 180°.

**Finish:** A 4-step process is applied to the exterior finish of all Kitchen Kompact Cabinets: Stain, Sealer, Sanding, and Catalyzed top coat. This finish is resistant to household chemicals such as water, beverages, mild acids – even nail polish. Richwood Lite, Chadwood2 "The Deuce," and K Wood all feature a special hand-wiped stain.

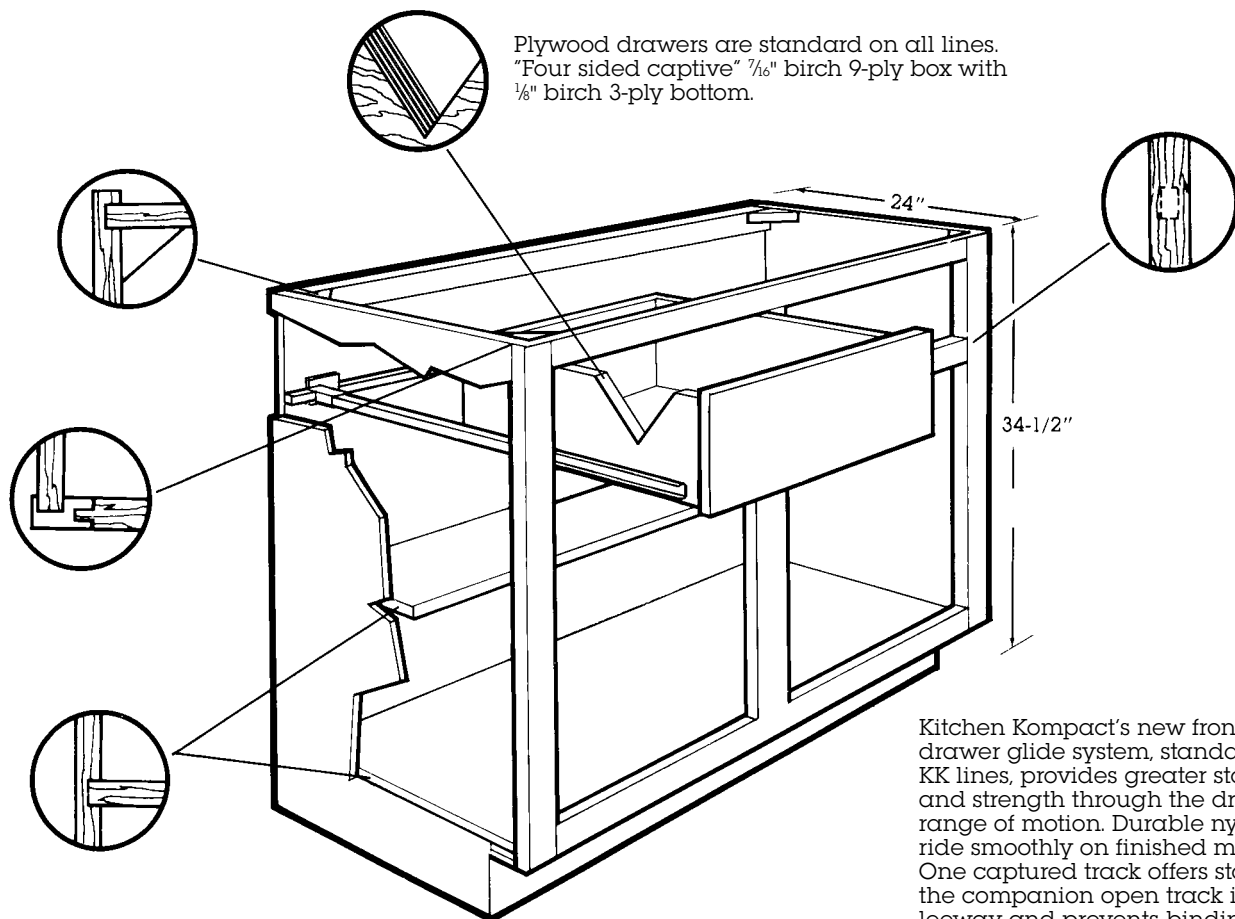

Plywood drawers are standard on all lines. "Four sided captive"  $\frac{7}{16}$ " birch 9-ply box with  $\frac{1}{8}$ " birch 3-ply bottom.

Kitchen Kompact's new front-to-back drawer glide system, standard on all KK lines, provides greater stability and strength through the drawer's full range of motion. Durable nylon rollers ride smoothly on finished metal runners. One captured track offers stability, while the companion open track increases leeway and prevents binding.

# KK Lazy Susan

Kitchen Kompact, Inc.  
911 E. 11th St. (47130)  
P.O. Box 868  
Jeffersonville, IN 47131-0868  
TEL: 812/282-6681  
FAX: 812/282-7880  
www.kitchenkompact.com



**Frames:** Solid  $\frac{3}{4}$ " oak or maple, kiln-dried rails, joined by mortise and tenon with glue.

**End Panels:** Not required unless cabinet is used at the end of a run.

**Toe Kick:**  $\frac{3}{4}$ " pine.

**Shelf:** Double-walled high impact polystyrene shelves have internal struts for maximum strength.

**Hardware:** Engineered with an adjustable mechanism (detail A) for aligning the vertical and rotational position of cabinet doors within the cabinet frame. The nylon gear and cam mechanism requires no lubrication.

**Finish:** A 4-step process is applied to the exterior finish of all Kitchen Kompact Cabinets: Stain, Sealer, Sanding, and Catalyzed top coat. This finish is resistant to household chemicals such as water, beverages, mild acids – even nail polish. Richwood Lite, Chadwood2 "The Deuce," and K Wood all feature a special hand-wiped stain.

